

VONGON

replay

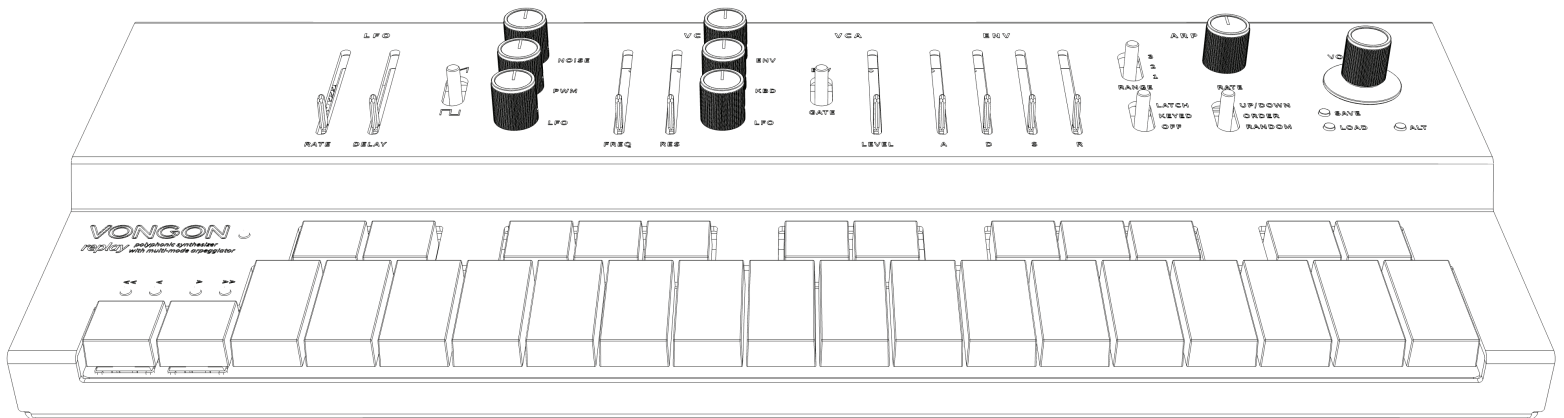

USER MANUAL

VERSION 1.0.1

INTRO

the **VONGON *replay*** is a polyphonic synthesizer with multi-mode arpeggiator inspired by the Roland Juno and the Korg Polysix of the early 1980s. designed to embody vintage character while utilizing modernity and versatility of form

replay has a six-voice virtual analog sound engine that emulates the organic response of an analog circuit - enabling you to create a diverse range of sounds from rich pads and vibrant leads to snappy arpeggios and deep sub-bass tones

balancing scope, style and function - ***replay*** has a slim footprint with 22 dedicated sound controls and a 2½-octave keyboard of genuine Cherry MX keys. the intuitive format and sleek design encourages an immersive, hands-on approach to creating your sonic palette

replay seamlessly integrates into your personalized setup with full MIDI I/O via 3.5mm jacks and USB connectivity. compatible with standard effect pedal power supply, ***replay*** connects effortlessly with your pedal board - streamlining your workflow for live performances, studio sessions, etc.

additionally, ***replay*** offers a user-friendly web interface. your command center for managing presets, accessing extended parameters and downloading the latest firmware updates

WHAT'S IN THE BOX?

- ✓ **VONGON *replay***
- ✓ power supply
- ✓ micro USB cable
- ✓ quickstart manual

ARP
ARPEGGIATOR

RANGE - octave range for arpeggio
MODE - sets operating mode. latch, keyed or off
RATE - speed notes are played in a sequence
ORDER - order notes are played in a sequence

ENV
ENVELOPE GENERATOR

A - attack time
D - decay time
S - sustain level
R - release time

VCA
VOLTAGE CONTROLLED AMPLIFIER

MODE - sets control signal for VCA. envelope, gate with release or gate
LEVEL - maximum level of VCA

VCF
VOLTAGE CONTROLLED FILTER

FREQ - cutoff frequency of filter
RES - filter resonance, filter self oscillates above 80%
ENV - frequency modulation from envelope generator
KBD - frequency modulation from OSC pitch 100% is a 1:1 keyboard tracking
LFO - frequency modulation from LFO

OSC
OSCILLATOR

WAVEFORM - output waveform of OSC
NOISE - level of white noise
PWM - pulse width modulation of the square wave
LFO - depth of pitch modulation

LFO
LOW FREQUENCY OSCILLATOR

RATE - frequency/speed of LFO
DELAY - time needed for the LFO to start to function after a key press

VOLUME - volume output of *replay*
SAVE - save preset to internal memory
LOAD - load preset from internal memory
ALT - access additional modes of *replay*

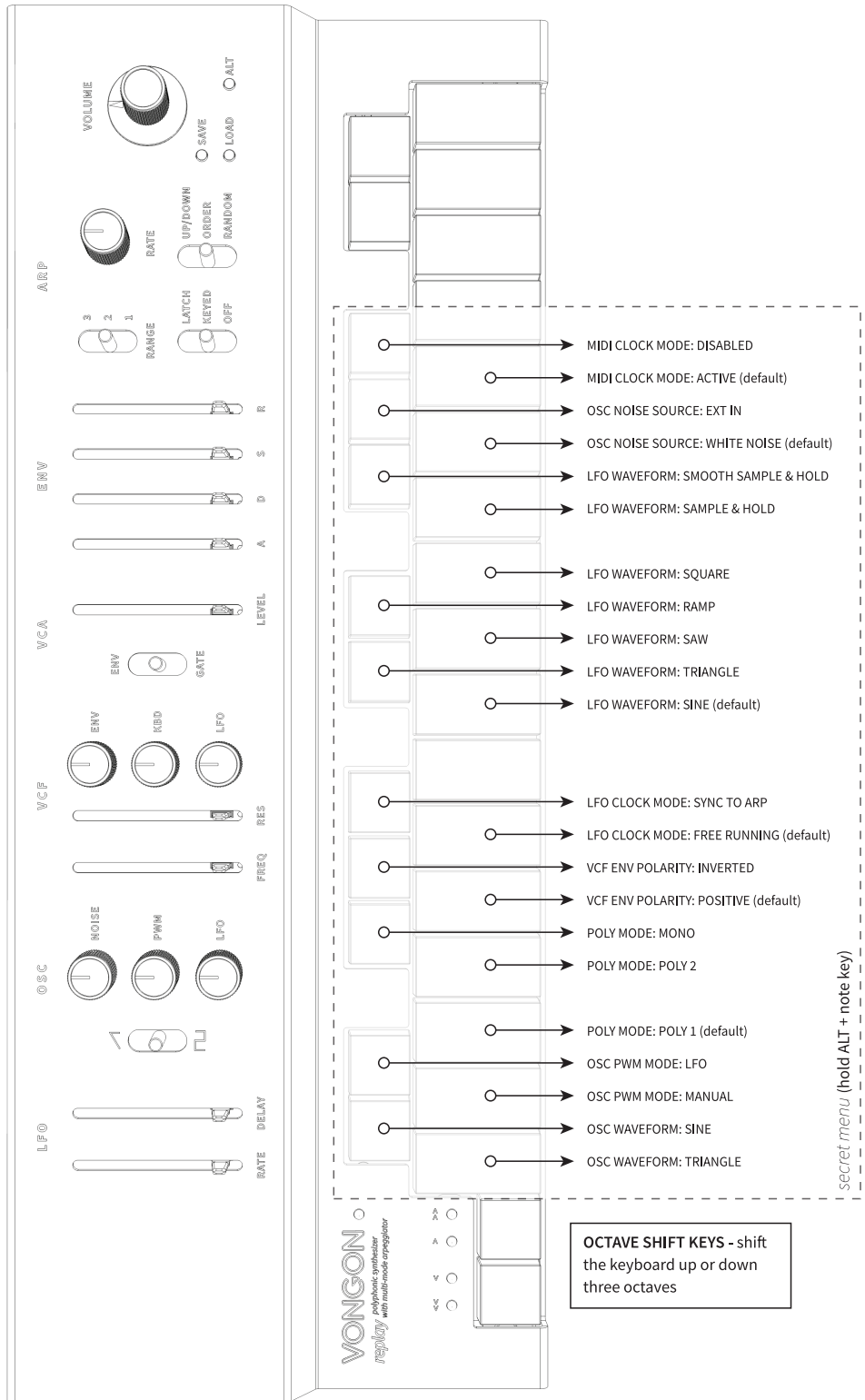

OUT

line level balanced 1/4" TRS audio output

EXT IN

line level balanced 1/4" TRS audio input

USB

micro USB connector for USB MIDI and *replay WEB Interface*

can be used as alternative power supply

MIDI

3.5mm MIDI IN/OUT for use with external sequencers, keyboard and other hardware

compatible with TYPE A or B MIDI adapters - configure in *replay WEB Interface*

9V DC

primary power connector for *replay*. standard effect pedal power supply, compatible with all **VONGON** pedals

2.1mm 9 Volt DC, Center Negative, 200mA Current Draw

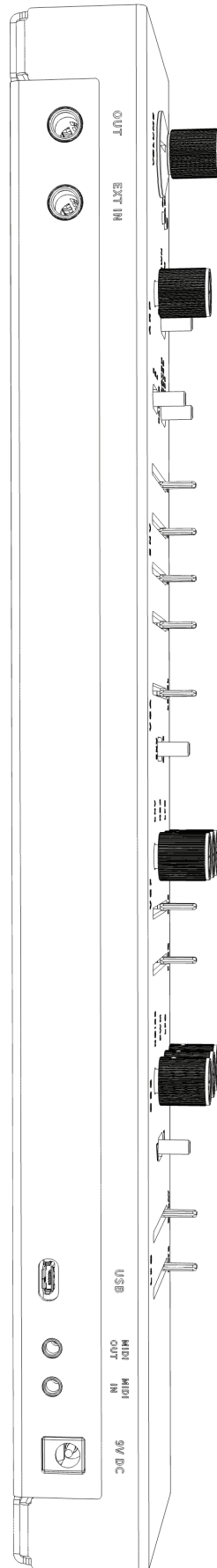

replay WEB Interface

use the **replay WEB Interface** to manage presets, update firmware, view and edit each parameter. to use the **replay WEB Interface**, connect your replay via USB and open the web page

FEATURES

- view and edit all controls (including secret menu)
- save/load presets as JSON file
- update firmware
- configure hardware MIDI channel and MIDI adapter type

URL

<https://replay.vongon.com>

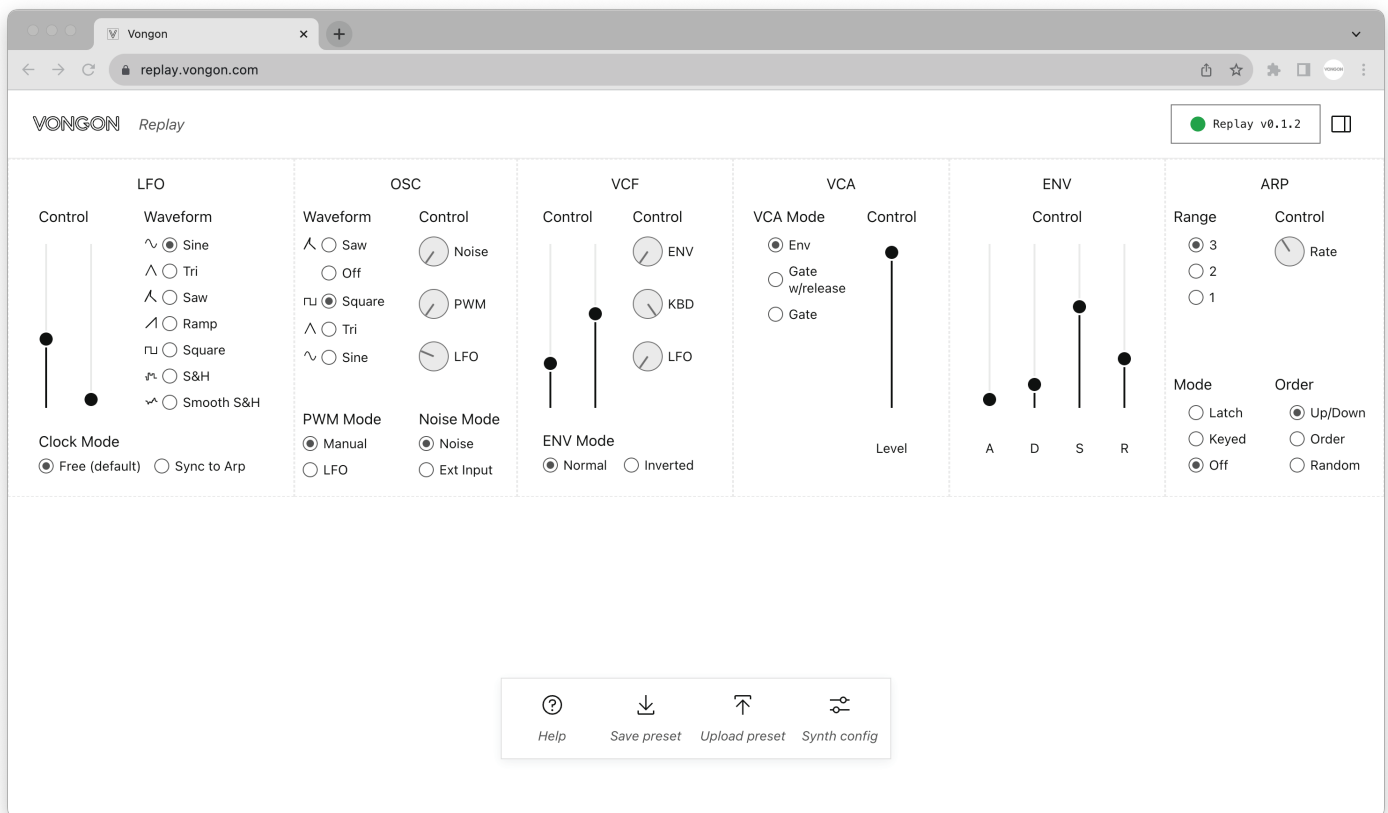

CONNECTIONS

POWER

replay ships with a universal DC power adapter. this standard effect pedal power supply will work with all **VONGON** pedals. if you are using your **replay** with an effect pedal - you can daisy chain the synth with the pedals, as seen on a typical pedal board

SPECS

2.1mm 9 Volt DC, Center Negative, 200mA Current Draw

AUDIO

replay has 1/4" TRS balanced audio input and output. it is perfectly safe to use unbalanced connections. if you experience noise from a power supply or USB connection, utilizing the balanced output will help resolve any issues

USB

replay has a micro USB port that was designed to be used with **replay WEB Interface**. you can also use the USB port for USB MIDI connection to your favorite DAW (digital audio workstation)

MIDI

replay has a 3.5mm MIDI input and output port. these ports can be configured to work with TYPE A or TYPE B adapters - adjust this setting in the **replay WEB Interface**

LFO

Low Frequency Oscillator

this oscillator generates only low frequency signals (0.1Hz to 30Hz) it can be used to modulate the OSC pitch or the VCF frequency

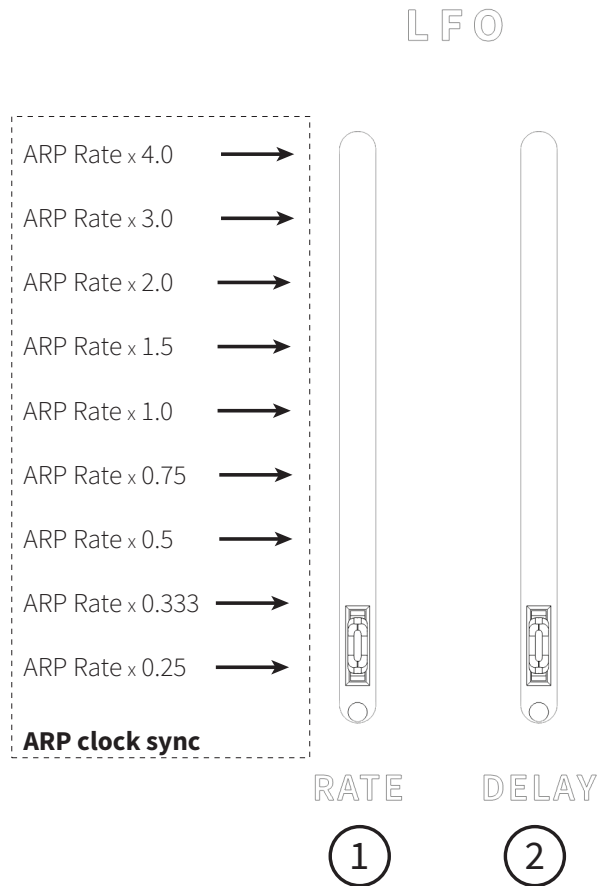

- ① **RATE** - sets the frequency/speed of LFO
- ② **DELAY** - sets the time needed for the LFO to fade into function after a key is pressed

waveforms

the LFO is set to sine wave by default, but additional waveforms can be accessed through the *secret menu* ALT controls or **replay** WEB Interface

ARP clock sync

sync the LFO clock with the ARP rate for rhythmic effects, this can be accessed through the *secret menu* ALT controls or **replay** WEB Interface

OSC

Oscillator

the OSC is the primary sound source of **replay**. each of the six voices are assigned to their corresponding OSC - producing four different waveforms, as well as a white noise generator

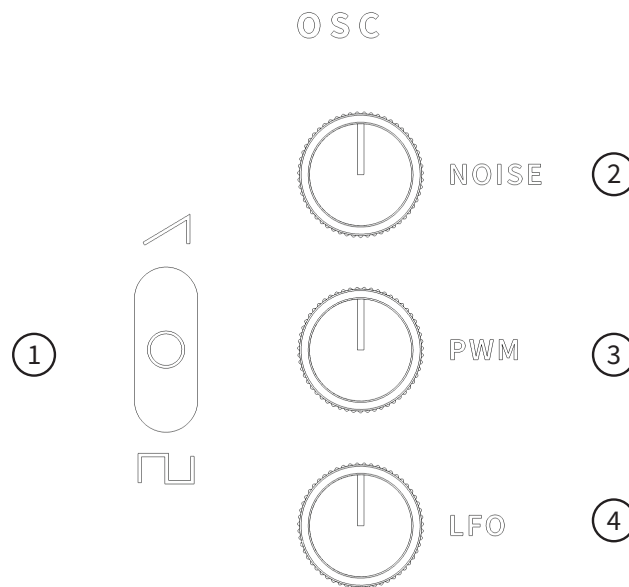

① **WAVEFORM** - sets the output waveform of the OSC. additional waveforms can be accessed through the *secret menu* ALT controls or **replay WEB Interface**

TOP - saw wave output

CENTER - mutes the OSC so that the noise or external audio input can be used by itself

BOTTOM - pulse wave output

② **NOISE/EXTERNAL INPUT LEVEL** - sets the level of the white noise or external audio input signal. configure the input mode through the *secret menu* ALT controls or **replay WEB Interface**

③ **PULSE WIDTH MODULATION** - this only affects the pulse wave (waveform in bottom position). it adjusts pulse width when set to manual mode, or the intensity of modulation from the LFO when set to LFO mode. adjust mode through the *secret menu* ALT controls or **replay WEB Interface**

④ **OSC LFO AMOUNT** - adjusts the depth of pitch modulation on the OSC output coming from the LFO

VCF

Voltage Controlled Filter

the VCF is a 4 pole resonant low pass ladder filter that changes the tone color by cutting off or emphasizing harmonics. this filter can also self-oscillate and be used as an additional sine wave oscillator

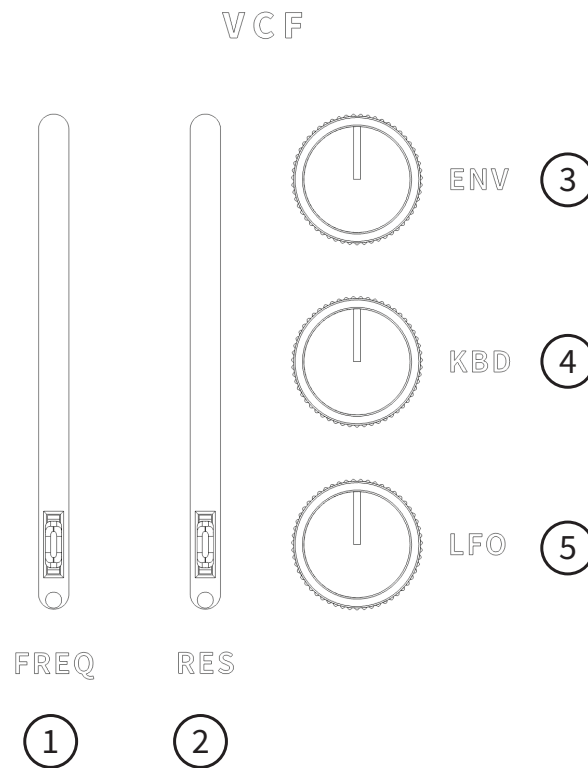

① **FREQUENCY** - sets the cutoff point of the filter. as you lower the slider, higher frequencies will be cut off and the sound will eventually fade out as you filter out all audible frequencies

② **RESONANCE** - this control emphasizes the cutoff point set by the frequency slider. as you raise the slider past 80% the filter will start to self oscillate

③ **ENVELOPE AMOUNT** - sets the amount of cutoff frequency modulation coming from the envelope. by default, the envelope adds to the cutoff frequency, but the envelope can be inverted through the *secret menu* ALT controls or **replay WEB Interface**

④ **KEYBOARD AMOUNT** - sets the amount of cutoff frequency modulation coming from the OSC pitch. this control can be used to make the filter brighter as you play higher notes. if you set this control to 100% the VCF frequency to OSC pitch modulation will be 1:1 so you can use the filter to harmonize with the notes that are played

⑤ **VCF LFO AMOUNT** - sets the amount of cutoff frequency modulation coming from the LFO

VCA

Voltage Controlled Amplifier

the VCA controls the volume or amplitude of the sound output from each voice

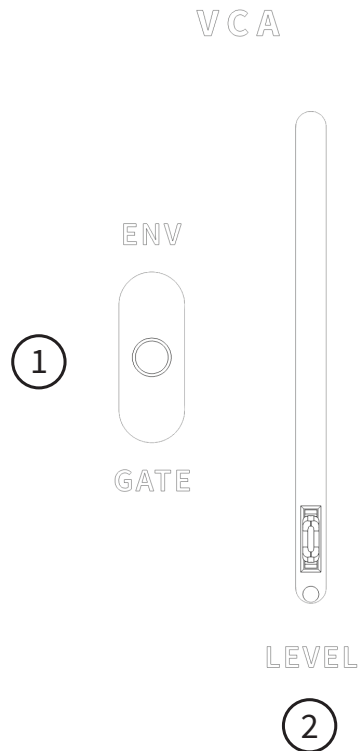

① **VCA MODE** - sets the control signal for the VCA

TOP (ENV) - sets the envelope output to control the VCA

CENTER (GATE with RELEASE) - combines the top and bottom controls to create a modified gate signal that matches the release of the envelope

BOTTOM (GATE) - sets the voice gate output to control the VCA

② **LEVEL** - sets the maximum level of the VCA. this control can be used to match the volume between presets

**NOTE - if you are hearing a clipping distortion when playing large chords, this parameter might be too high and can cause distortion when all 6 voices are added together*

ENV

Envelope Generator

the envelope generates a control signal which is applied to the VCF and VCA - controlling the volume and the tone of each note. this signal is generated whenever you press a key or trigger a note with the ARP

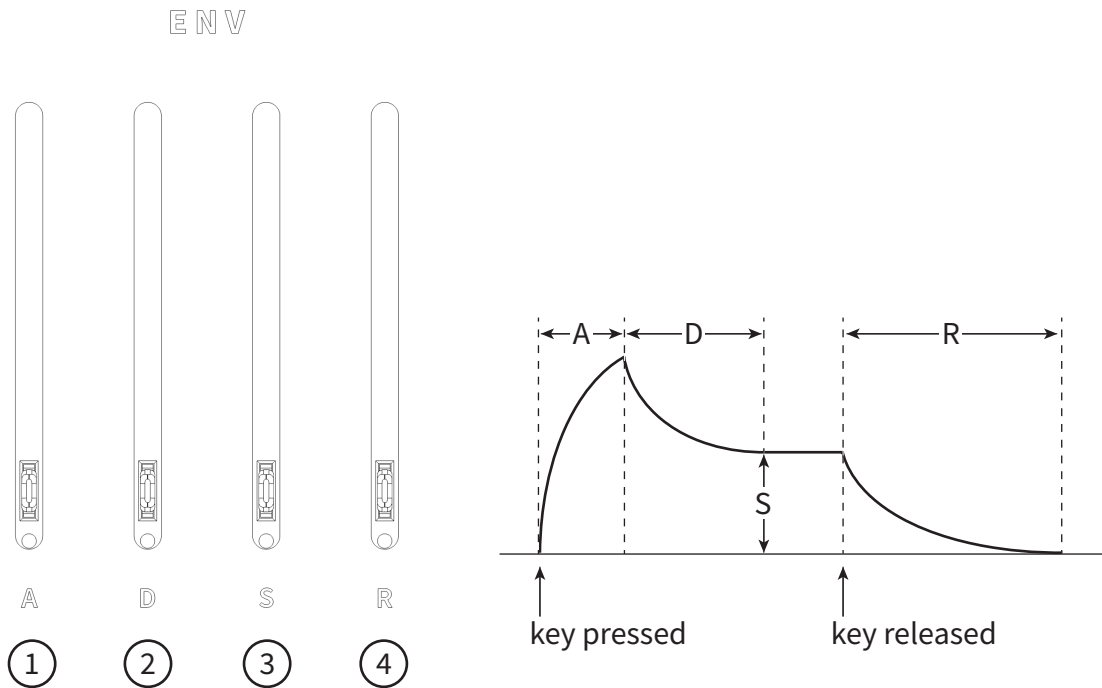

- ① **ATTACK** - sets the time required for the ENV to reach its maximum from the moment it is triggered
- ② **DECAY** - sets the time required for the ENV to drop from the maximum to the sustain level. when the sustain level is high, the decay time has no effect
- ③ **SUSTAIN** - sets the sustain level when a key is held
- ④ **RELEASE** - sets the time required for the ENV to reach zero after a key is released

ARP

Arpeggiator

the arpeggiator automatically sequences individual notes of a chord at the users desired speed, in three different patterns

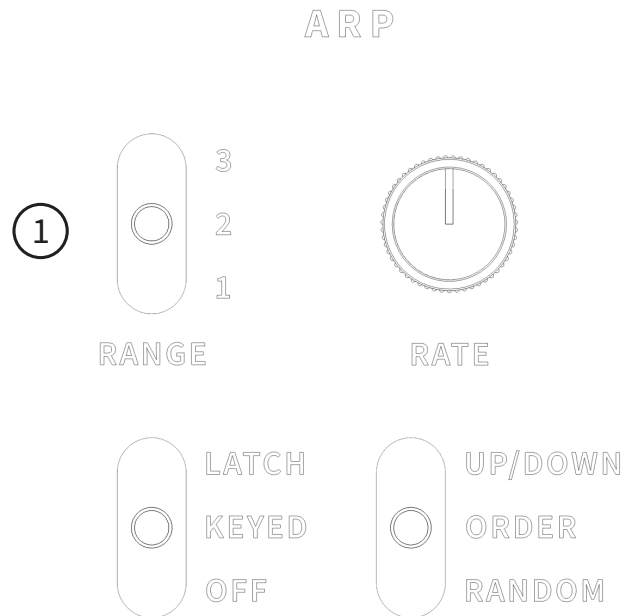

① OCTAVE RANGE

TOP (3) - arpeggiates the notes held or latched, plus the same notes on the second and third higher octaves

CENTER (2) - arpeggiates the notes held or latched, plus the same notes on the second higher octave

BOTTOM (1) - arpeggiates only the notes notes held or latched

ARP (continued)

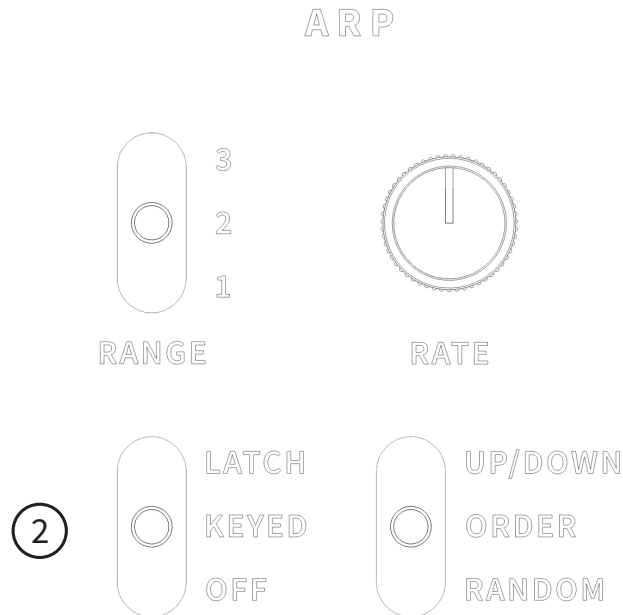

② ARP MODE

TOP (LATCH) - notes played are memorized or latched and will continue to be arpeggiated when you release the key. the latch behavior changes based on the current poly mode - set through the *secret menu* ALT controls or **replay WEB Interface**

POLY MODE 1 - all key presses will add to the set of notes arpeggiated. clear the latched set by switching the mode to keyed or off. you can hold a chord while switching the mode from latched to keyed for a smooth transition into a new chord

POLY MODE 2 - key presses will add to the set of arpeggiated notes if at least one key is held down. when all keys are released, a new key press will clear the ARP note set and create a new chord. this mode makes it more convenient to quickly switch between arpeggiated chords

CENTER (KEYED) - only notes that are currently held down will be arpeggiated

BOTTOM (OFF) - arpeggiator is off

ARP (continued)

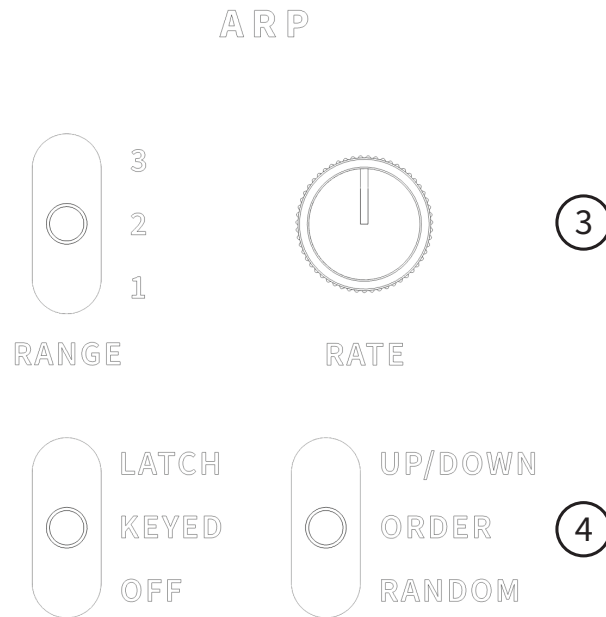

③ **ARP RATE** - sets the speed at which the arpeggio is played. when no MIDI clock is detected, the range is from (0.1Hz to 30Hz) when MIDI clock is detected, the ARP will trigger based on the MIDI clock signals received

**see MIDI Beat Sync (page 15)*

④ **NOTE ORDER** - sets the order notes are played in the arpeggio

TOP (UP/DOWN)- notes are played ascending then descending

CENTER (ORDER) - notes are played in the order they were pressed

BOTTOM (RANDOM) - notes are played at random

ARP (continued)

24_{PPQ} = 1 quarter note

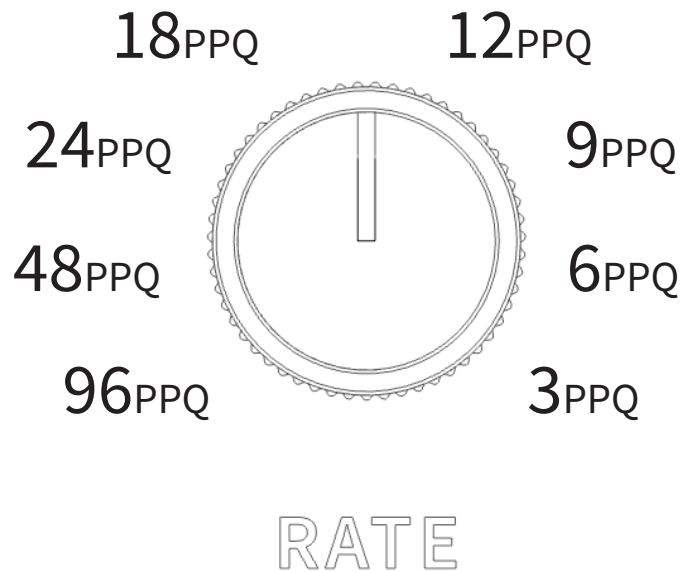

MIDI BEAT SYNC - when a MIDI clock signal is detected the ARP will *beat sync* to the clock source in the standard 24_{PPQ} (pulse per quarter note) format. this style of *beat sync* will count the MIDI clock messages and trigger a new note when the threshold, set by the rate knob, has been reached. when pressing a note slightly before the downbeat, the ARP will wait until the PPQ threshold has passed to play your note - keeping the phase of your arpeggio in sync with the clock source

**NOTE - when you decrease the threshold to 6_{PPQ} or lower, the ARP is more sensitive to MIDI clock jitter, which can translate into rhythmic jitter. if this happens, try decreasing the number of MIDI devices in your chain or use usb MIDI to increase performance*

- *set the rate knob to 24_{PPQ} - note every quarter note
- *set the rate knob to 12_{PPQ} - note every eighth note
- *set the rate knob to 6_{PPQ} - note every sixteenth note
- *MIDI start and reset commands will reset the ARP *beat sync* counter

MAIN

VOLUME

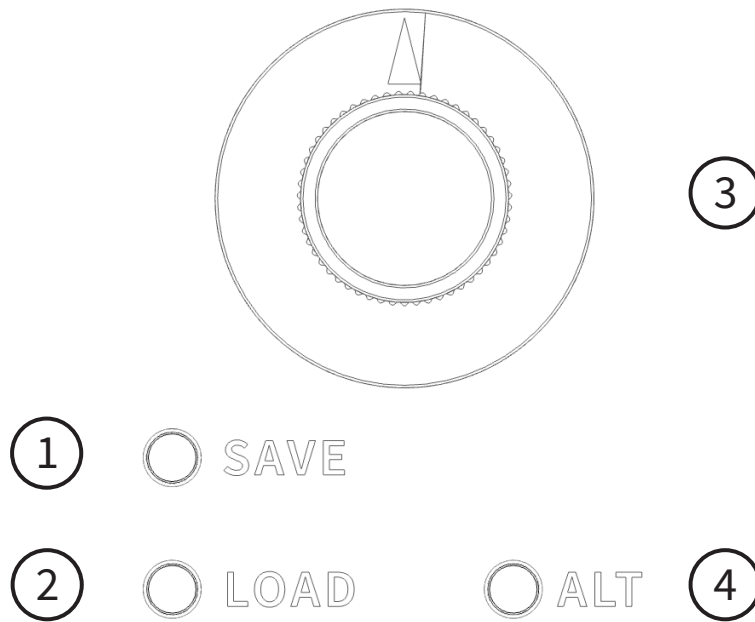

① **SAVE** - use this button to save a **replay** preset onto the internal memory

② **LOAD** - use this button to load a **replay** preset from the internal memory

**see Presets (page 17)*

③ **VOLUME** - sets the volume output of **replay**. this parameter is the global volume control and is not saved into presets

④ **ALT** - use this button to access the *secret menu*

**see secret menu (page 18)*

PRESETS

you can save *replay* presets in two ways

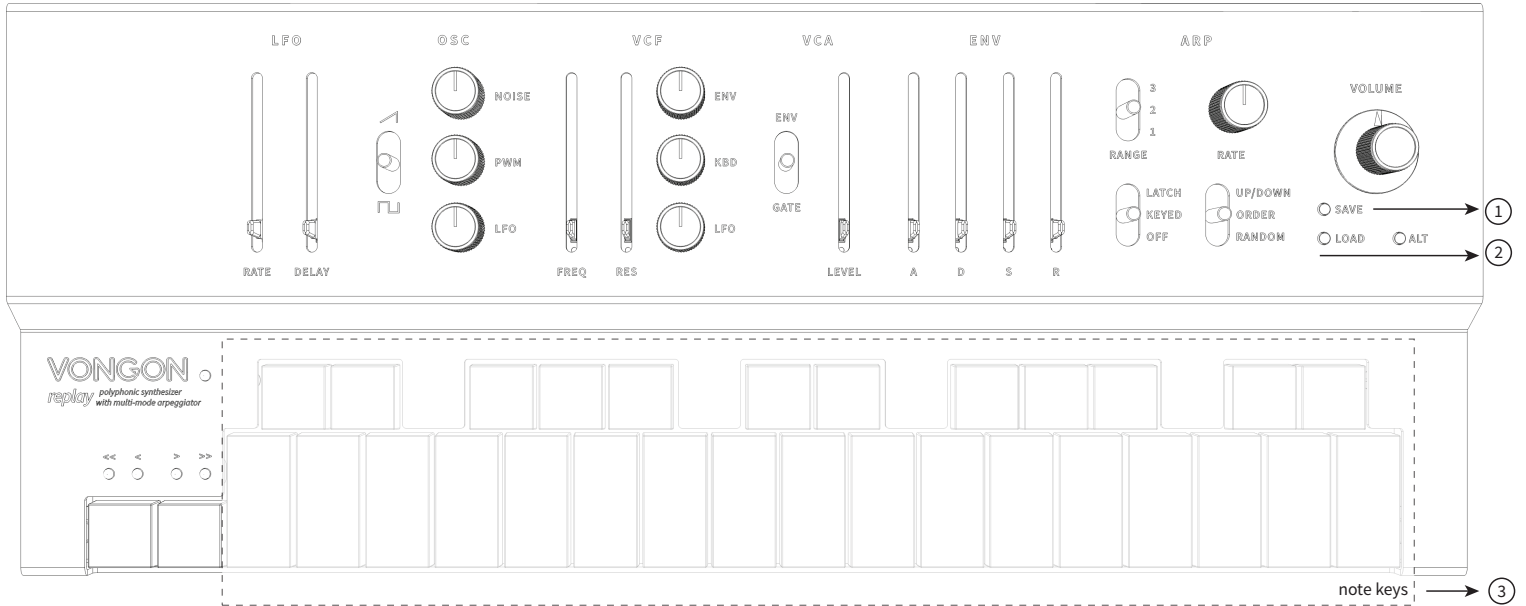

HARDWARE PRESETS - allows quick access to your favorite sounds (ideal for live performances) *replay* can store up to 29 presets (one per note key) in its internal storage

① **SAVE** - hold down the SAVE button, then press and hold the desired preset note key for three seconds. the purple VONGON LED will blink slowly three times - confirming the preset has been saved

② **LOAD** - hold down the LOAD button, then press the desired preset note key. the purple VONGON LED will blink rapidly - confirming the preset has been loaded

③ **NOTE KEY** - any note key can be used as a preset

SOFTWARE PRESETS - connect *replay* via USB to save and load presets through the *replay* WEB Interface on your computer. you can view, create, save and load presets to build your own library of your favorite sounds and share your presets with other *replay* users

secret menu

the ALT button enables you to access additional modes on the **replay** secret menu. all of these parameters can be saved into a preset for easy access and are visible on the **replay** WEB Interface

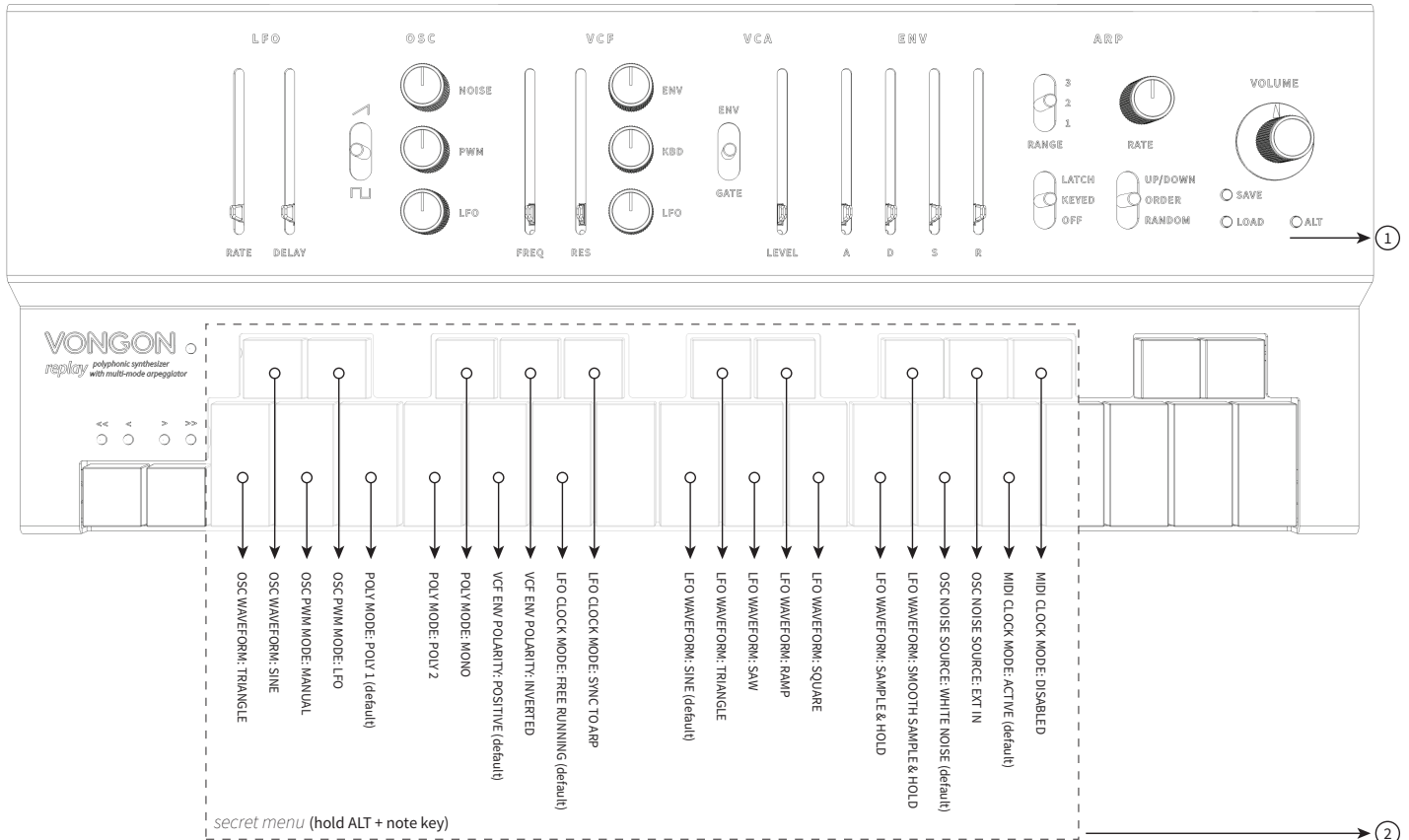

① **ALT** - hold down the ALT button to access the **replay** secret menu, then press a note key. the four white octave LEDs will blink rapidly - confirming that the corresponding mode was selected

② ALT FUNCTIONS DEFINED

- MIDI CLOCK MODE** - enable or disable the **replay** to recognize MIDI clock
- OSC NOISE SOURCE** - choose the signal source for the NOISE knob. by default, the source is white noise. if you enable the EXT IN, the NOISE knob will set the volume level of the incoming audio from the EXT IN input jack
- LFO WAVEFORM** - modify the LFO waveform for a variety of modulation effects ie. sine, triangle, saw, ramp, square, sample & hold, or smooth sample & hold
- VCF ENV POLARITY** - ENV will increase (positive) or decrease (inverted) the VCF cutoff frequency

secret menu (continued)

POLY MODE - voice allocation modes

POLY 1 - keeps all notes ringing as long as possible - think playing a piano with the sustain pedal pushed down. when playing a new note, if all 6 voices are already held down (playing a six note chord), no new notes will be heard. if any voices are released but still sounding from their release stage, the oldest released voice will be reassigned to the new note

POLY 2 - ideal for chord changes that you don't want bleeding into previously played chords - particularly useful when playing low notes that can get muddy. when playing a new note, this mode will respond as POLY 1 unless all keys have been released, then all voices in the release stage will be muted

MONO - single voice mono synth, priority given to the most recent key pressed

OSC PWM MODE - determines the way the OSC PWM knob works. in manual mode, the knob statically adjusts the pulse wave of OSC. in LFO mode, the knob adjusts the depth of LFO modulation on the pulse wave of OSC, creating chorus-like sounds

OSC WAVEFORM - adds sine and triangle waveforms to the OSC

SIGNAL FLOW

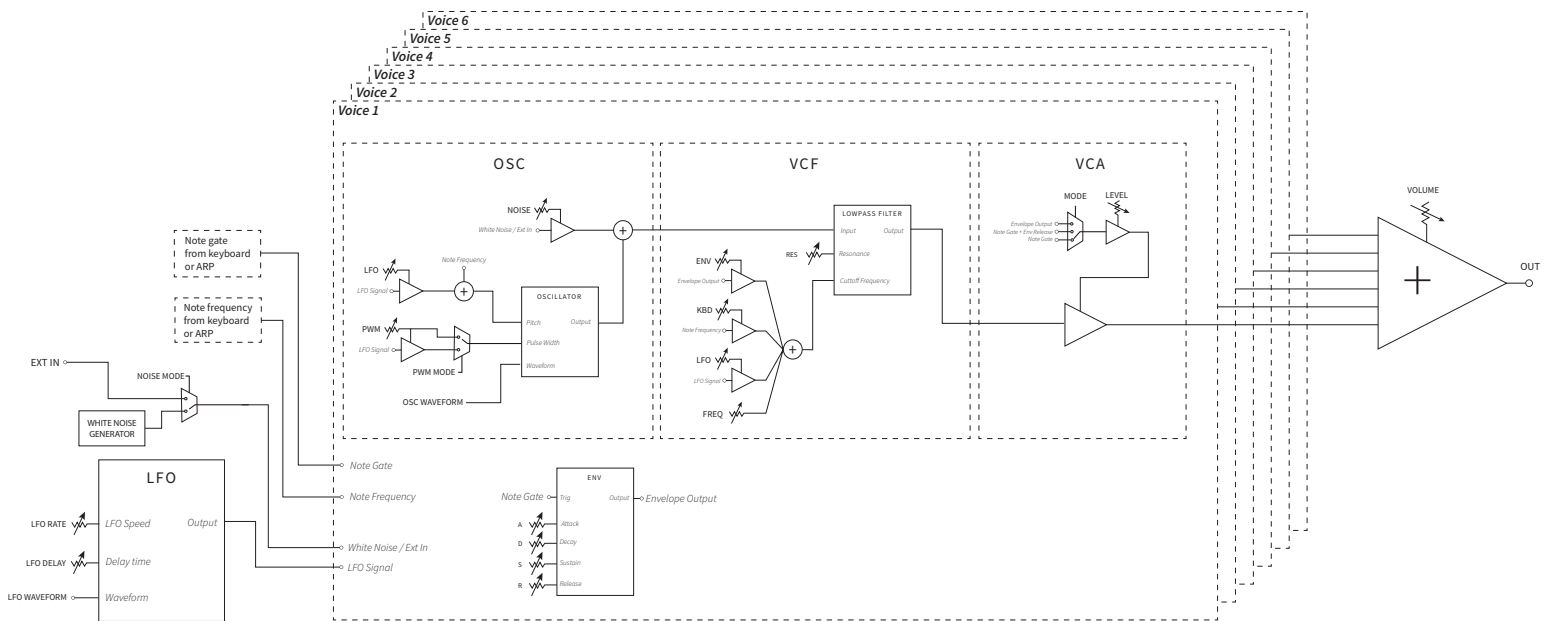

MIDI

use 3.5mm MIDI ports or USB port to interact with **replay** MIDI controls

MIDI ADAPTER - by default, **replay** expects TYPE A style MIDI adapters. you can switch the MIDI adapter type to TYPE B with the **replay WEB Interface**

MIDI CHANNEL - to assign a MIDI channel to **replay**, use the **replay WEB Interface** or use MIDI channel learn mode. power up the device while holding ALT - the four white octave LEDs will blink, indicating that **replay** is in MIDI channel learn mode. **replay** will assign itself to the MIDI channel of the next incoming MIDI message

MIDI CLOCK SYNC - **replay** can sync the ARP and LFO to the MIDI clock, see those sections above for details

**see details (page 7, 15)*

MIDI (continued)

CONTINUOUS CONTROLLER MESSAGES

MIDI MESSAGE	PARAMETER	VALUES	SEND	RECEIVE
CC# 85	LFO RATE	0-127	<input checked="" type="checkbox"/>	<input checked="" type="checkbox"/>
CC# 88	LFO DELAY	0-127	<input checked="" type="checkbox"/>	<input checked="" type="checkbox"/>
CC# 83	OSC WAVEFORM	0: Saw, 1: Off, 2: Square, 3: Tri, 4: Sine	<input checked="" type="checkbox"/>	<input checked="" type="checkbox"/>
CC# 84	OSC NOISE	0-127	<input checked="" type="checkbox"/>	<input checked="" type="checkbox"/>
CC# 87	OSC LFO	0-127	<input checked="" type="checkbox"/>	<input checked="" type="checkbox"/>
CC# 92	OSC PWM	0-127	<input checked="" type="checkbox"/>	<input checked="" type="checkbox"/>
CC# 74	VCF FREQ	0-127	<input checked="" type="checkbox"/>	<input checked="" type="checkbox"/>
CC# 71	VCF RES	0-127	<input checked="" type="checkbox"/>	<input checked="" type="checkbox"/>
CC# 75	VCF ENV	0-127	<input checked="" type="checkbox"/>	<input checked="" type="checkbox"/>
CC# 86	VCF LFO	0-127	<input checked="" type="checkbox"/>	<input checked="" type="checkbox"/>
CC# 81	VCF KBD	0-127	<input checked="" type="checkbox"/>	<input checked="" type="checkbox"/>
CC# 80	VCA MODE	0-127	<input checked="" type="checkbox"/>	<input checked="" type="checkbox"/>
CC# 91	VCA LEVEL	0-127	<input checked="" type="checkbox"/>	<input checked="" type="checkbox"/>
CC# 76	ENV ATTACK	0-127	<input checked="" type="checkbox"/>	<input checked="" type="checkbox"/>
CC# 77	ENV DECAY	0-127	<input checked="" type="checkbox"/>	<input checked="" type="checkbox"/>
CC# 78	ENV SUSTAIN	0-127	<input checked="" type="checkbox"/>	<input checked="" type="checkbox"/>
CC# 79	ENV RELEASE	0-127	<input checked="" type="checkbox"/>	<input checked="" type="checkbox"/>
CC# 100	ARP RANGE	0: 1 Octave, 1: 2 Octaves, 2: 3 Octaves	<input checked="" type="checkbox"/>	<input checked="" type="checkbox"/>
CC# 101	ARP MODE	0: Off, 1: Keyed, 2: Latch	<input checked="" type="checkbox"/>	<input checked="" type="checkbox"/>
CC# 102	ARP RATE	0-127	<input checked="" type="checkbox"/>	<input checked="" type="checkbox"/>
CC# 103	ARP ORDER	0: Up/Down, 1: Order, 2: Random	<input checked="" type="checkbox"/>	<input checked="" type="checkbox"/>
CC# 104	MAIN VOLUME	0-127	<input checked="" type="checkbox"/>	<input checked="" type="checkbox"/>
CC# 40	POLY MODE	0: Poly 1, 1: Poly 2, 2: Mono	<input checked="" type="checkbox"/>	<input checked="" type="checkbox"/>
CC# 41	LFO WAVEFORM	0: Sine, 1: Tri, 2: Saw, 3: Ramp, 4: Square, 5: S&H, 6: Smooth S&H	<input checked="" type="checkbox"/>	<input checked="" type="checkbox"/>
CC# 42	LFO CLOCK MODE	0: Free running, 1: Sync to ARP	<input checked="" type="checkbox"/>	<input checked="" type="checkbox"/>
CC# 43	OSC PWM MODE	0: Manual, 1: LFO	<input checked="" type="checkbox"/>	<input checked="" type="checkbox"/>
CC# 44	VCF ENV POLARITY	0: Normal, 1: Inverted	<input checked="" type="checkbox"/>	<input checked="" type="checkbox"/>
CC# 45	OSC NOISE MODE	0: Noise knob controls white noise level 1: Noise knob controls EXT IN level	<input checked="" type="checkbox"/>	<input checked="" type="checkbox"/>
CC# 46	MIDI CLOCK MODE	0: Enabled (MIDI Clock affects ARP Rate) 1: Disabled (ARP rate is normal)	<input checked="" type="checkbox"/>	<input checked="" type="checkbox"/>
CC# 10	Octave Up Key	0-127	<input type="checkbox"/>	<input checked="" type="checkbox"/>
CC# 11	Octave Down Key	0-127	<input type="checkbox"/>	<input checked="" type="checkbox"/>
CC# 12	Save Button	0-127	<input type="checkbox"/>	<input checked="" type="checkbox"/>
CC# 13	Load Button	0-127	<input type="checkbox"/>	<input checked="" type="checkbox"/>
CC# 14	Alt Button	0-127	<input type="checkbox"/>	<input checked="" type="checkbox"/>

SWITCH REPLACEMENT

replay ships from the factory with Cherry MX Black style switches. the keyboard uses hot-swap sockets so that you can replace the switches with any MX compatible style switch to modify actuation force, tactile feedback, and noise level

IMPORTANT* disconnect the power cable and replace one switch at a time. this will keep the assembly safe, sturdy and easy to work with

① **REMOVE KEYCAP** - using a key puller, remove the keycap

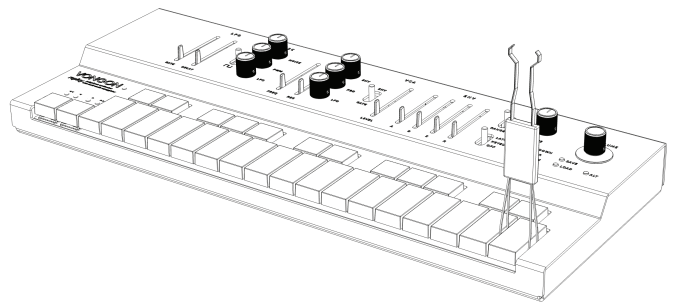

② **REMOVE SWITCH** - using a switch puller, remove the switch

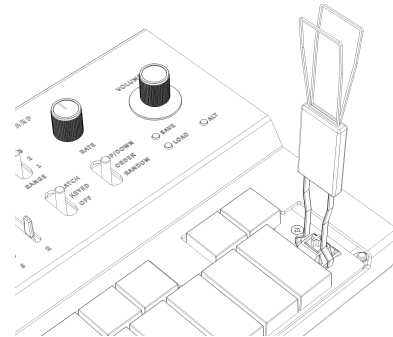

③ **INSERT NEW SWITCH** - insert the new switch, making sure that the electrical contacts go into the switch socket

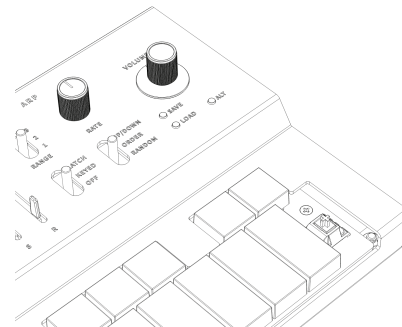

④ **REINSERT KEYCAP** - press the keycap down on the newly inserted switch

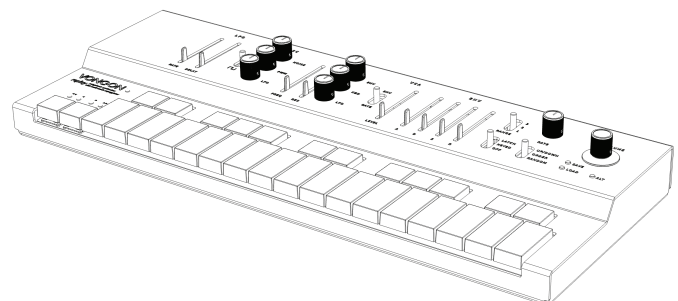

EXTENDED WARRANTY & SUPPORT

VONGON will repair or replace any malfunctioning product one year from purchase date. problems resulting from modification or misuse may void this warranty. this warranty applies only to the original owner of the product - proof of purchase required. we will happily diagnose and repair any VONGON product - even if out of warranty (shipping and repairs at owners expense)

CONTACT

please feel free to reach out with any questions or concerns
support@vongon.com

CHANGE LOG

VERSION	DATE	DESCRIPTION
v1.0	Jan 5, 2024	Initial commit
v1.0.1	Feb 29, 2024	Add switch replacement process